



AVTECH ELECTROSYSTEMS LTD.

NANOSECOND WAVEFORM ELECTRONICS  
SINCE 1975

P.O. BOX 265  
OGDENSBURG, NY  
U.S.A. 13669-0265  
TEL: (315) 472-5270  
FAX: (613) 226-2802

TEL: 1-800-265-6681  
FAX: 1-800-561-1970

e-mail: [info@avtechpulse.com](mailto:info@avtechpulse.com)  
<http://www.avtechpulse.com/>

BOX 5120, LCD MERIVALE  
OTTAWA, ONTARIO  
CANADA K2C 3H4  
TEL: (613) 226-5772  
FAX: (613) 226-2802

## INSTRUCTIONS

MODEL AVO-6C-C

0 TO 5 Amp (0 to 250 Volts)

10 kHz LASER DIODE DRIVER

SERIAL NUMBER: \_\_\_\_\_

### WARRANTY

Avtech Electrosystems Ltd. warrants products of its manufacture to be free from defects in material and workmanship under conditions of normal use. If, within one year after delivery to the original owner, and after prepaid return by the original owner, this Avtech product is found to be defective, Avtech shall at its option repair or replace said defective item. This warranty does not apply to units which have been disassembled, modified or subjected to conditions exceeding the applicable specifications or ratings. This warranty is the extent of the obligation assumed by Avtech with respect to this product and no other warranty or guarantee is either expressed or implied.

### TECHNICAL SUPPORT

Phone: 613-226-5772 or 1-800-265-6681

Fax: 613-226-2802 or 1-800-561-1970

E-mail: [info@avtechpulse.com](mailto:info@avtechpulse.com)

World Wide Web: <http://www.avtechpulse.com>

## TABLE OF CONTENTS

<b>WARRANTY.....</b>	<b>2</b>
<b>TECHNICAL SUPPORT.....</b>	<b>2</b>
<b>TABLE OF CONTENTS.....</b>	<b>3</b>
<b>INTRODUCTION.....</b>	<b>5</b>
<b>SPECIFICATIONS.....</b>	<b>6</b>
<b>EC DECLARATION OF CONFORMITY.....</b>	<b>7</b>
<b>INSTALLATION.....</b>	<b>8</b>
<b>VISUAL CHECK.....</b>	<b>8</b>
<b>POWER RATINGS.....</b>	<b>8</b>
<b>CONNECTION TO THE POWER SUPPLY.....</b>	<b>8</b>
<b>ENVIRONMENTAL CONDITIONS.....</b>	<b>8</b>
<b>FUSES.....</b>	<b>9</b>
<b>AC FUSE REPLACEMENT.....</b>	<b>9</b>
<b>DC FUSE REPLACEMENT.....</b>	<b>10</b>
<b>FUSE RATINGS.....</b>	<b>10</b>
<b>FRONT PANEL CONTROLS.....</b>	<b>11</b>
<b>REAR PANEL CONTROLS.....</b>	<b>13</b>
<b>GENERAL INFORMATION.....</b>	<b>14</b>
<b>AMPLITUDE CONTROL.....</b>	<b>14</b>
<b>BASIC PULSE CONTROL.....</b>	<b>15</b>
<b>LENZ'S LAW AND INDUCTIVE VOLTAGE SPIKES.....</b>	<b>16</b>
<b>BASIC TEST ARRANGEMENT - WITHOUT OUTPUT MODULE.....</b>	<b>16</b>
<b>BASIC TEST ARRANGEMENT - WITH OUTPUT MODULE.....</b>	<b>17</b>
<b>MECHANICAL INFORMATION.....</b>	<b>19</b>
<b>TOP COVER REMOVAL.....</b>	<b>19</b>
<b>ELECTROMAGNETIC INTERFERENCE.....</b>	<b>19</b>
<b>MAINTENANCE.....</b>	<b>20</b>
<b>REGULAR MAINTENANCE.....</b>	<b>20</b>
<b>CLEANING.....</b>	<b>20</b>
<b>PERFORMANCE CHECK SHEET.....</b>	<b>21</b>

Last modified March 1, 2004.  
Copyright © 2004 Avtech Electrosystems Ltd. All Rights Reserved.

## INTRODUCTION

The AVO-6C-C is a high performance instrument capable of generating 0 to 5.0 A at repetition rates up to 10 kHz. The pulse width is variable from 50 ns to 5 us, and the duty cycle may be as high as 1%. Rise and fall times are fixed at less than 10 ns. The AVO-6C-C includes an internal trigger source, but it can also be triggered by an external source.

The AVO-6C-C consists of two parts, the mainframe and the output module. The mainframe is a voltage pulser, which generates 0 to +250V ( $V_{OUT}$ ). The output module contains a  $49\Omega$  series resistance. The diode load is connected in series with this resistance, so that the current through the diode is normally given by:

$$I_{DIODE} = (V_{OUT} - V_{DIODE}) / 49\Omega$$

where  $V_{DIODE}$  is the voltage drop across the diode. An additional resistance ( $R_{SENSE}$ ) can be placed in series with the load, for current monitoring purposes. In this case, the diode current is given by:

$$I_{DIODE} = (V_{OUT} - V_{DIODE}) / (49\Omega + R_{SENSE})$$

Alternatively, a fast current probe may be used to monitor the current waveform. Factory testing is conducted using a Tektronix CT2 or Pearson 2878 current transformer. (This technique tends to introduce less waveform distortion than the sensing resistor method.)

This instrument is intended for use in research and development laboratories.

## SPECIFICATIONS

Model:	AVO-6C-C
Amplitude:	"-P" units: 0 to +5.0 A (0 to +250 Volts into 49 Ohms + diode) "-N" units: 0 to -5.0 A (0 to -250 Volts into 49 Ohms + diode) "-PN" units: 0 to $\pm$ 5.0 A (0 to $\pm$ 250 Volts into 49 Ohms + diode)
Pulse width:	50 ns to 5 us
Rise time:	$\leq$ 10 ns
Fall time:	$\leq$ 10 ns
PRF:	0 Hz to 10 kHz
Duty cycle (maximum):	1%
Propagation delay:	$\leq$ 100 ns (Ext trig in to pulse out)
Jitter:	$\pm$ 100 ps (Ext trig in to pulse out)
Trigger required:	Internal Mode: +5 Volt, 50 ns or wider (TTL)
Sync delay:	Sync out to pulse out: Variable 0 to $\pm$ 5 us
Sync output:	+ 3 Volts, 200 ns, will drive 50 Ohm loads
Connectors:	Out: solder terminals, Trig: BNC
Power, AC:	100 - 240 Volts, 50 - 60 Hz
Dimensions:	Mainframe: 100 x 215 x 375 mm (3.9" x 8.5" x 14.8") Output Module: 41 x 66 x 76 mm (1.6" x 2.6" x 3.0")
Chassis material:	anodized aluminum, with blue plastic trim
Mounting:	Any
Temperature range:	+5° to +40° C

EC DECLARATION OF CONFORMITY

We

Avtech Electrosystems Ltd.  
P.O. Box 5120, LCD Merivale  
Ottawa, Ontario  
Canada K2C 3H4

declare that this pulse generator meets the intent of Directive 89/336/EEC for Electromagnetic Compatibility. Compliance pertains to the following specifications as listed in the official Journal of the European Communities:

EN 50081-1 Emission

EN 50082-1 Immunity

and that this pulse generator meets the intent of the Low Voltage Directive 72/23/EEC as amended by 93/68/EEC. Compliance pertains to the following specifications as listed in the official Journal of the European Communities:

EN 61010-1:2001 Safety requirements for electrical equipment for measurement, control, and laboratory use



## INSTALLATION

### VISUAL CHECK

After unpacking the instrument mainframe and the transformer module, examine to ensure that they have not been damaged in shipment. Visually inspect all connectors, knobs, and handles. Confirm that a power cord and an instrumentation manual (this manual), are with the instrument. If the instrument has been damaged, file a claim immediately with the company that transported the instrument.

### POWER RATINGS

This instrument is intended to operate from 100 - 240 V, 50 - 60 Hz.

The maximum power consumption is 57 Watts. Please see the "FUSES" section for information about the appropriate AC and DC fuses.

This instrument is an "Installation Category II" instrument, intended for operation from a normal single-phase supply.

### CONNECTION TO THE POWER SUPPLY

An IEC-320 three-pronged recessed male socket is provided on the back panel for AC power connection to the instrument. One end of the detachable power cord that is supplied with the instrument plugs into this socket. The other end of the detachable power cord plugs into the local mains supply. Use only the cable supplied with the instrument. The mains supply must be earthed, and the cable used to connect the instrument to the mains supply must provide an earth connection. (The supplied cable does this.)

### ENVIRONMENTAL CONDITIONS

This instrument is intended for use under the following conditions:

- 1) indoor use;
- 2) altitude up to 2 000 m;
- 3) temperature 5 °C to 40 °C;
- 4) maximum relative humidity 80 % for temperatures up to 31 °C decreasing linearly to 50 % relative humidity at 40 °C;
- 5) Mains supply voltage fluctuations up to  $\pm 10$  % of the nominal voltage;
- 6) no pollution or only dry, non-conductive pollution.



## FUSES

This instrument contains four fuses. All are accessible from the rear-panel. Two protect the AC prime power input, and two protect the internal DC power supplies. The locations of the fuses on the rear panel are shown in the figure below:

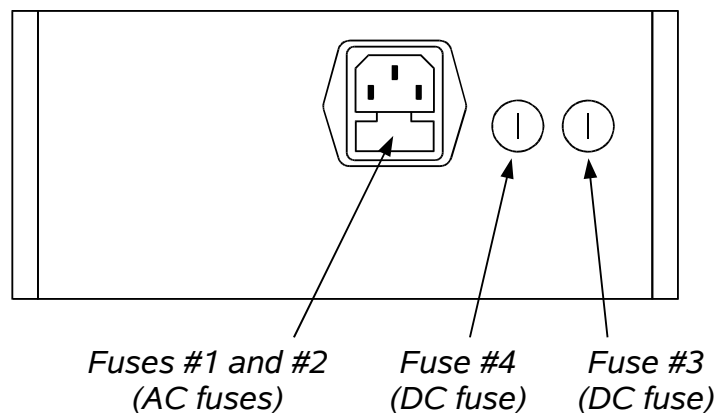

### AC FUSE REPLACEMENT

To physically access the AC fuses, the power cord must be detached from the rear panel of the instrument. The fuse drawer may then be extracted using a small flat-head screwdriver, as shown below:

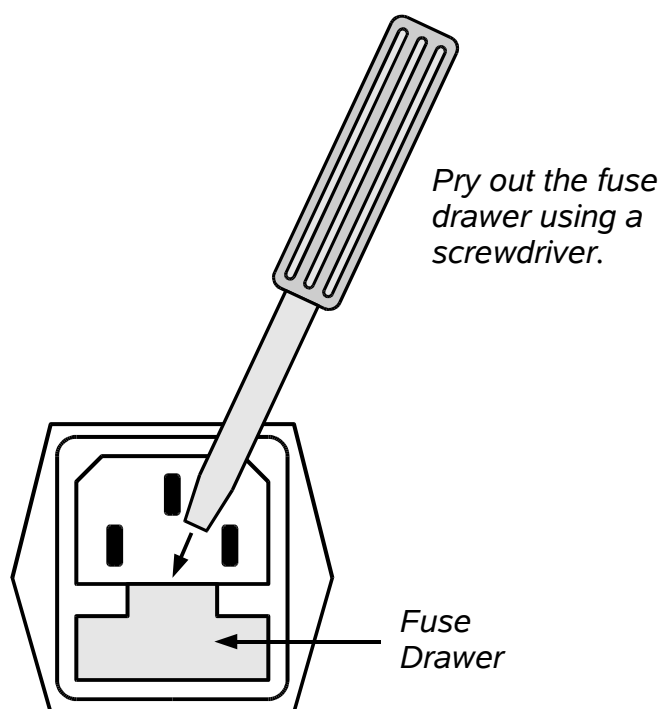

## DC FUSE REPLACEMENT

The DC fuses may be replaced by inserting the tip of a flat-head screwdriver into the fuse holder slot, and rotating the slot counter-clockwise. The fuse and its carrier will then pop out.

## FUSE RATINGS

The following table lists the required fuses:

Fuses	Nominal Mains Voltage	Rating	Case Size	Manufacturer's Part Number (Wickmann)	Distributor's Part Number (Digi-Key)
#1, #2 (AC)	100-240V	0.5A, 250V, Time-Delay	5×20 mm	1950500000	WK5041-ND
#3 (DC)	N/A	1.6A, 250V, Time-Delay	5×20 mm	1951160000	WK5053-ND
#4 (DC)	N/A	1.0A, 250V, Time-Delay	5×20 mm	1951100000	WK5048-ND

The fuse manufacturer is Wickmann (<http://www.wickmann.com/>).

Replacement fuses may be easily obtained from Digi-Key (<http://www.digikey.com/>) and other distributors.

## FRONT PANEL CONTROLS

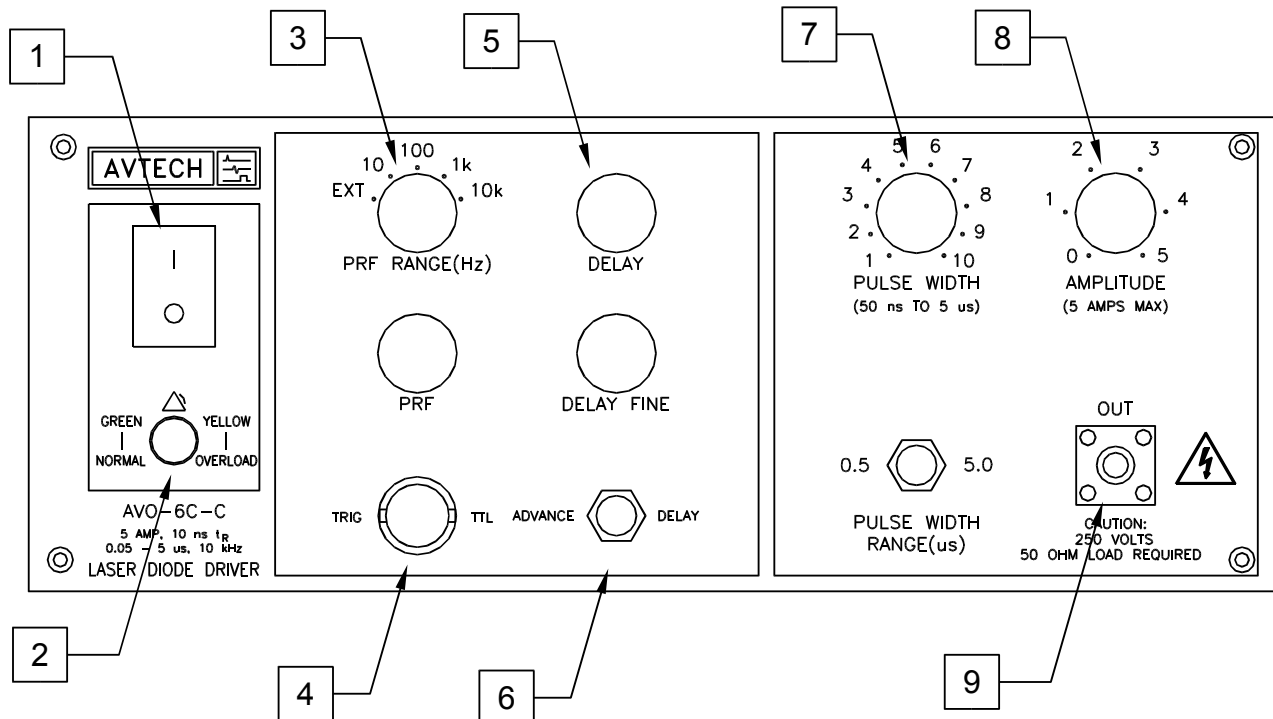

- 1) POWER Switch. This is the main power switch. When turning the instrument on, there may be a delay of several seconds before the instrument appears to respond.
- 2) OVERLOAD Indicator. When the instrument is powered, this indicator is normally green, indicating normal operation. If this indicator is yellow, an internal automatic overload protection circuit has been tripped. If the unit is overloaded (by operating at an exceedingly high duty cycle or by operating into a very low impedance), the protective circuit will disable the output of the instrument and turn the indicator light yellow. The light will stay yellow (i.e. output disabled) for about 5 seconds after which the instrument will attempt to re-enable the output (i.e. light green) for about 1 second. If the overload condition persists, the output will be disabled again (i.e. light yellow) for another 5 seconds. If the overload condition has been removed, the instrument will resume normal operation.

This overload indicator may flash yellow briefly at start-up. This is not a cause for concern.

- 3) PRF Range Switch. This switch sets the pulse repetition frequency (PRF) range of the internal oscillator. The marked value of each position is the upper limit of the 10:1 range, approximately. The vernier dial directly below the switch varies the PRF within the set range.

If this switched is set to the "EXT" position, the instrument is triggered by a signal

applied to the TRIG connector, rather than by the internal oscillator.

- 4) TRIG Connector. When the PRF Range Switch is set to “EXT”, the instrument is triggered by a TTL pulse applied to this connector. The pulse must be at least 50 ns wide.

When the PRF Range Switch is set to one of the four internal oscillator ranges, this connector is an output, which supplies a 2V, 200 ns wide pulse for each trigger event. This output may be used to trigger oscilloscopes or other equipment.

- 5) Delay Controls. When the PRF Range Switch is set to one of the four internal oscillator ranges, the main output is advanced or delayed relative to the TRIG output pulse (item 3). The delay is variable up to 200 ns, approximately, using the DELAY and DELAY FINE dials.
- 6) Advance/Delay Switch. When the PRF Range Switch is set to one of the four internal oscillator ranges, this switch determines whether the TRIG output precedes the main output (ADVANCE mode), or whether the TRIG output occur after the main output (DELAY mode).
- 7) Pulse Width Controls. This dial and switch combination controls the pulse width.
- 8) Amplitude Control. This dial controls the pulse amplitude.
- 9) Out Connector. This SMA connector is connected to the output module, when the output module is used to drive a diode load. If the output module is not used, this output will generate up to 250V into a load impedance of 50Ω.



Caution: Voltages as high as  $\pm 250\text{V}$  may be present on the center conductor of this output connector. Avoid touching this conductor. Connect to this connector using standard coaxial cable, to ensure that the center conductor is not exposed.

### REAR PANEL CONTROLS

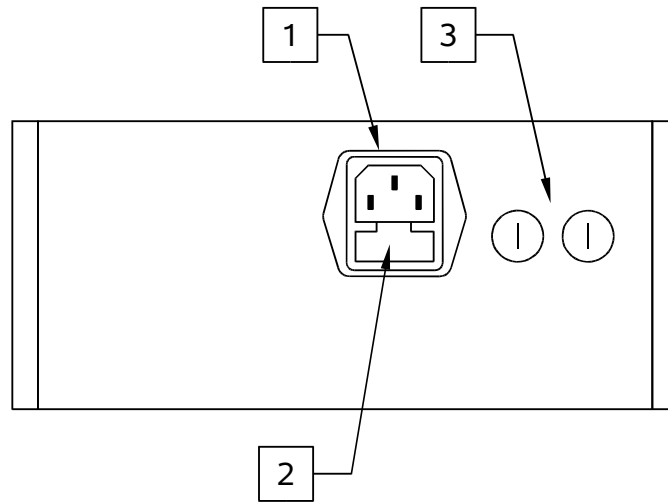

1. AC POWER INPUT. An IEC-320 C14 three-pronged recessed male socket is provided on the back panel for AC power connection to the instrument. One end of the detachable power cord that is supplied with the instrument plugs into this socket.
2. AC FUSE DRAWER. The two fuses that protect the AC input are located in this drawer. Please see the “FUSES” section of this manual for more information.
3. DC FUSES. These two fuses protect the internal DC power supplies. Please see the “FUSES” sections of this manual for more information.

## GENERAL INFORMATION

### AMPLITUDE CONTROL

The AVO-6C-C consists of two parts, the mainframe and the output module. The mainframe is a voltage pulser, which generates 0 to +250V (assuming that the model is a “-P” positive unit, or a dual-polarity model operating in the positive mode). The output module contains a 49Ω series resistance. The diode load is connected in series with this resistance, so that the current through the diode is normally given by:

$$I_{\text{DIODE}} = (V_{\text{OUT}} - V_{\text{DIODE}}) / 49\Omega$$

where  $V_{\text{DIODE}}$  is the voltage drop across the diode.

The functional equivalent circuit of the output module is shown below:

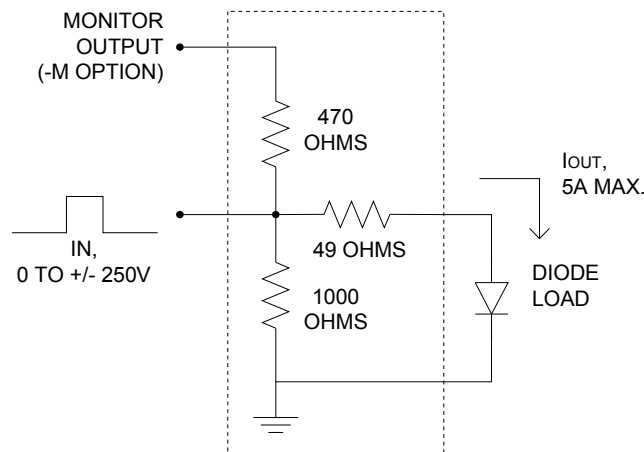

*Output Module Functional Equivalent Circuit*

(The equivalent circuit is shown for positive outputs. For “-N” instruments, and the negative output circuit of the dual-polarity “-PN” instruments, the polarities are negative and diodes are reversed in direction.)

On units with the -M option, a monitor output is provided, as shown above. When the monitor output is terminated with a 50 Ohm resistance, the monitor output provides an attenuated (approximately 20 dB) replica of the input signal to the output module.

An additional resistance ( $R_{\text{SENSE}}$ ) can be placed in series with the diode load, for current monitoring purposes. In this case, the diode current is given by:

$$I_{\text{DIODE}} = (V_{\text{OUT}} - V_{\text{DIODE}}) / (49\Omega + R_{\text{SENSE}})$$

Alternatively, a fast current probe may be used to monitor the current waveform. Factory testing is conducted using a Tektronix CT2 or Pearson 2878 current

transformer. (This technique tends to introduce less waveform distortion than the sensing resistor method.)

### BASIC PULSE CONTROL

This instrument can be triggered by its own internal clock or by an external TTL trigger signal. When triggered internally, two mainframe output channels respond to the trigger: OUT and SYNC.

- OUT. This is the main output. The maximum output voltage is 20V.
- TRIG. The TRIG pulse is a fixed-width TTL-level reference pulse used to trigger oscilloscopes or other measurement systems.

When the ADVANCE/DELAY switch is set to “ADVANCE”, the TRIG output precedes the main output. These pulses are illustrated below:

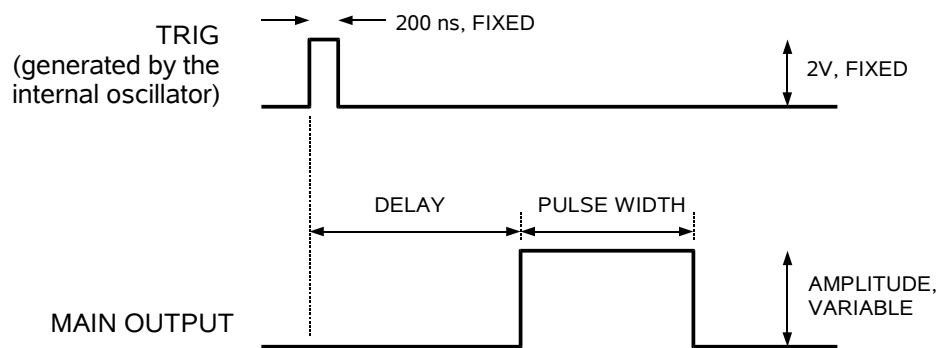

When the ADVANCE/DELAY switch is set to “DELAY”, the TRIG output occurs after the main output. This is illustrated below:

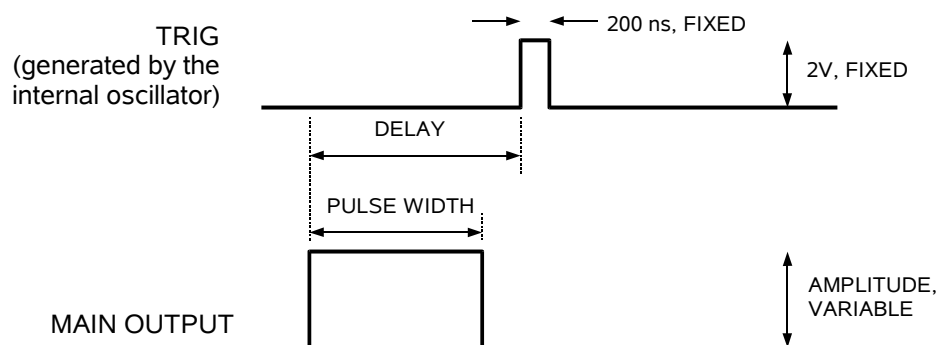

When triggered externally, the TRIG connector acts as an input. The delay controls do not function in this mode. This illustrated below:

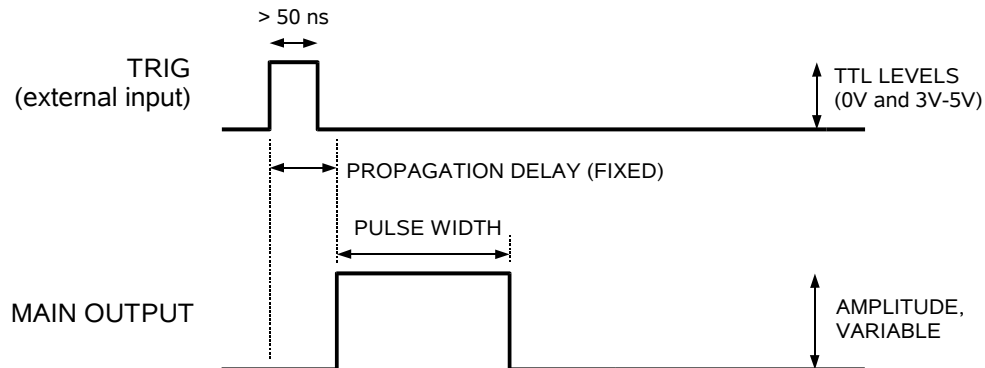

### LENZ'S LAW AND INDUCTIVE VOLTAGE SPIKES

This instrument is designed to pulse resistive and diode loads and will exhibit a large output spike when used to drive a load with significant inductance (as predicted by LENZ'S LAW). For this reason the load should be connected to the output using low inductance leads (as short as possible).

The voltage developed across an inductance  $L$  (in Henries), when the current is changing at a rate given by  $di_{LOAD} / dt$  (in Amps/sec), is:  $V_{SPIKE} = L di_{LOAD} / dt$ .

### BASIC TEST ARRANGEMENT - WITHOUT OUTPUT MODULE

The AVO-6C-C can be tested initially without the supplied output module. If the output module is not used, the mainframe output generates 0 to +250 Volts (for -P units), or 0 to -250V (for -N units), into a 50 Ohm load, as illustrated below:

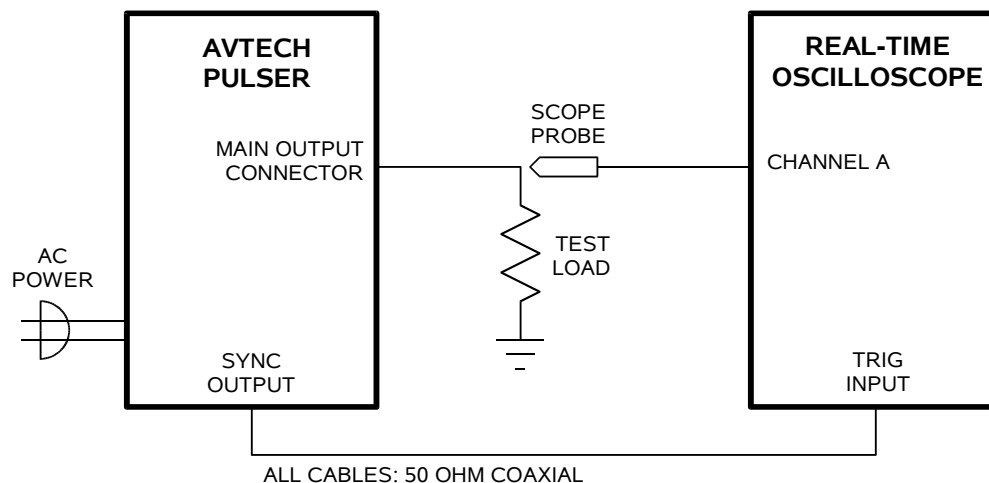



The load resistor must have a voltage rating of at least 250V, and a power rating of at least 12 Watts. It must also be low-inductance, or the waveform will become distorted and exhibit noticeable ringing.

### BASIC TEST ARRANGEMENT - WITH OUTPUT MODULE

To fully test the instrument, and for normal operation, the output module must be connected as shown below:

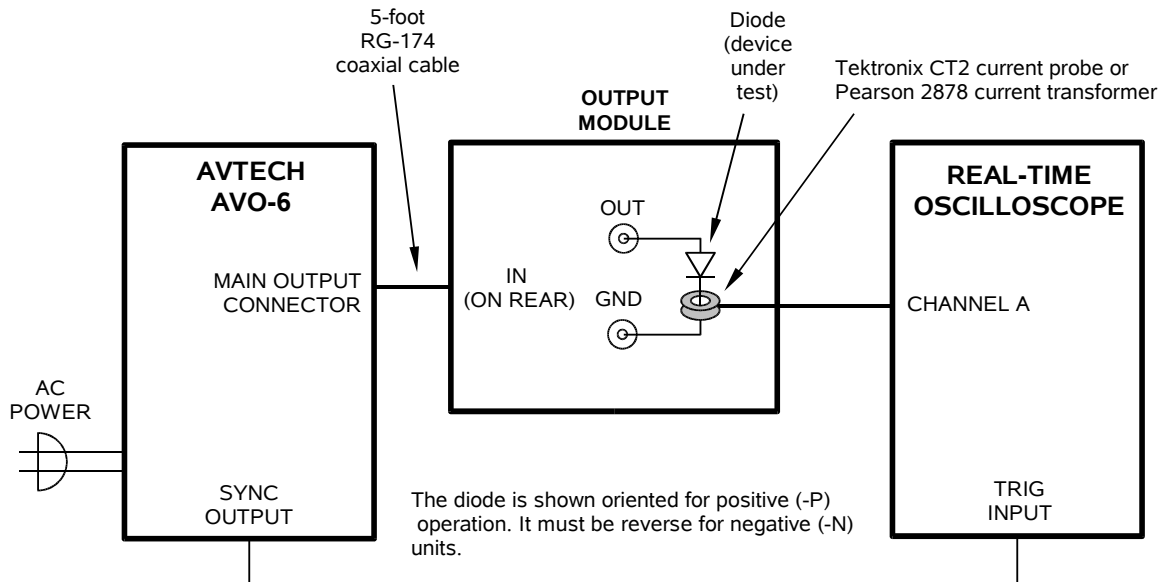

If a Tektronix CT2 current probe or Pearson 2878 current transformer is not available to measure the output current waveform, a 1 Ohm resistor may be used to sense the current instead. However, noticeable ringing and distortion may appear on the waveform if this technique is used. (The use of a Tektronix CT2 current probe or Pearson 2878 current transformer is strongly recommended for this reason.) This alternative test arrangement is shown below:

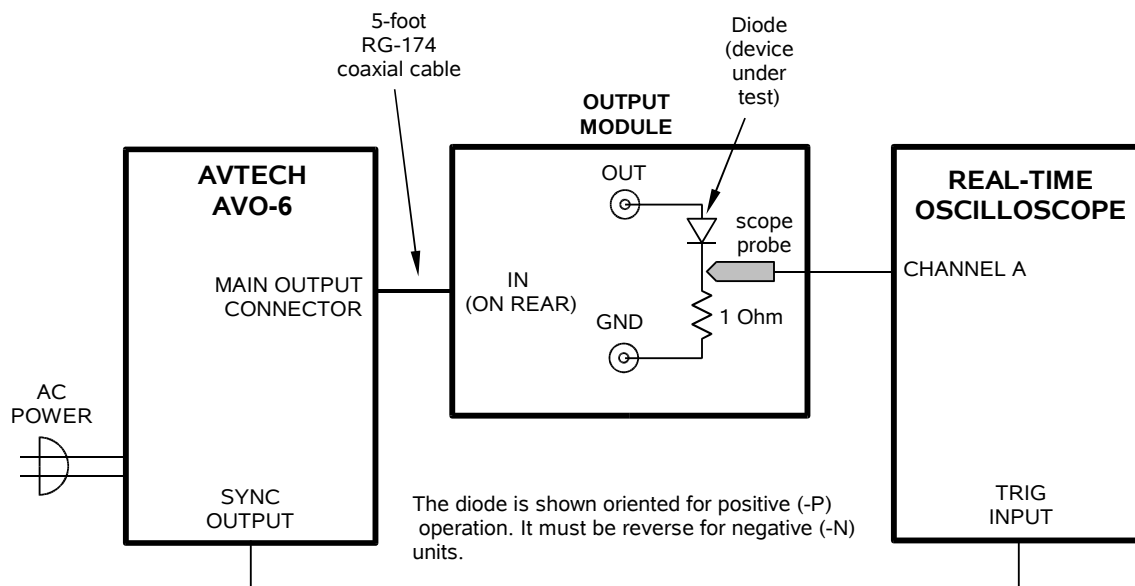

## MECHANICAL INFORMATION

### TOP COVER REMOVAL

If necessary, the interior of the instrument may be accessed by removing the four Phillips screws on the top panel. With the four screws removed, the top cover may be slid back (and off).

Always disconnect the power cord before opening the instrument.

There are no user-adjustable internal circuits. For repairs other than fuse replacement, please contact Avtech ([info@avtechpulse.com](mailto:info@avtechpulse.com)) to arrange for the instrument to be returned to the factory for repair.



Caution: High voltages are present inside the instrument during normal operation. Do not operate the instrument with the cover removed.

### ELECTROMAGNETIC INTERFERENCE

To prevent electromagnetic interference with other equipment, all used outputs should be connected to shielded 50Ω loads using shielded 50Ω coaxial cables. Unused outputs should be terminated with shielded 50Ω coaxial terminators or with shielded coaxial dust caps, to prevent unintentional electromagnetic radiation. All cords and cables should be less than 3m in length.

## MAINTENANCE

### REGULAR MAINTENANCE

This instrument does not require any regular maintenance.

On occasion, one or more of the four rear-panel fuses may require replacement. All fuses can be accessed from the rear panel. See the “FUSES” section for details.

### CLEANING

If desired, the interior of the instrument may be cleaned using compressed air to dislodge any accumulated dust. (See the “TOP COVER REMOVAL” section for instructions on accessing the interior.) No other cleaning is recommended.

PERFORMANCE CHECK SHEET